

EN

COMAU

# Racer-5

COBOT



**Racer5**  
COBOT

# Comau HUMANufacturing

## Collaboration is the new automation

Industry 4.0. The factory is changing to become a network of flexible, modular and scalable automation systems that are capable of operating autonomously or in a secure synergistic way with operators, always connected and under control.

As a world leader in advanced automation solutions, Comau has always improved manufacturing scenarios through up-to-date and human-centric technologies, capable of enhancing the social and environmental sustainability of the workplaces.

Automation is no longer confined within barriers, but it collaborates with human beings: this is what we like to call Comau HUMANufacturing, the new concept of human-machine collaboration.



## Discover Racer-5-0.80 COBOT

### Features

- **5 kg** payload
- **0.809 m** reach
- **0.03 mm** repeatability
- Collaborative/non-collaborative **speed switch**
- Up to **500 mm/s** cartesian speed in collaborative mode
- Up to **6 m/s** cartesian speed in non-collaborative mode
- Safe Collision Detection function - **PL d CAT. 3** certified by TÜV Süd

### Benefits

- High **repeatability** and **accuracy**
- Racer-5 Industrial robot speed when no human operator near by for an **increased productivity**
- Electrical and air **connections near the wrist** avoiding external harness
- Immediate **awareness** of cobot status due to LED stripe
- Long **life cycle** thanks to mechanical robustness
- **Efficiency** and **flexibility** of the cycle
- **Reduction** of **spaces** for automation
- **Simplified** process **inspection** and quality control

# Racer-5-0.80 COBOT supports humans as they perform manual operations, by optimizing the work process.

Hand guidance enabling button

User button

Electrical & air services integrated on robot wrist:

- RJ45 Ethernet + 2 digital inputs & 2 digital outputs
- Direct air + electrovalve

LED stripe for COBOT status

- GREEN:** collaborative mode
- Blinking Green:** manual guidance mode or programming mode.
- Blinking BLUE:** automatic restart after collision.
- RED:** System alarm
- NO LED:** full speed mode

The diagram illustrates the Racer-5-0.80 COBOT with various callouts. On the left, a side view of the robot arm is shown with a 'Hand guidance enabling button' on the upper arm. In the center, a top-down view of the robot arm highlights a 'User button' and 'Electrical & air services integrated on robot wrist', which includes 'RJ45 Ethernet + 2 digital inputs & 2 digital outputs' and 'Direct air + electrovalve'. On the right, a vertical stack of four images shows the robot's base with different LED stripe colors: green, blinking green, blinking blue, and red. Below these images, a legend explains the status: 'LED stripe for COBOT status'. The legend includes: 'GREEN: collaborative mode', 'Blinking Green: manual guidance mode or programming mode.', 'Blinking BLUE: automatic restart after collision.', 'RED: System alarm', and 'NO LED: full speed mode'. At the bottom right, a blue box contains the text 'FULL - COLLABORATIVE SPEED SWITCH (Controller option + Safety device installed)' and 'Compliant to ISO/TS 15066 - Tested by Tuv Rheinland', accompanied by an image of a SICK sensor device.

**Full speed mode is dynamically managed, when collaboration is not required**

**FULL - COLLABORATIVE SPEED SWITCH**  
(Controller option + Safety device installed)

- Compliant to ISO/TS 15066 - Tested by Tuv Rheinland

# Technical features

VERSION		Racer-5-0.80 COBOT
Structure / No. of axes		Anthropomorphic / 6 axes
Maximum wrist load		5 kg
Nominal wrist load		1 kg
Axis 4 torque		8,83 Nm
Axis 5 torque		8,83 Nm
Axis 6 torque		4,91 Nm
Admissible inertia on axis 4*		0,42 kg x m <sup>2</sup>
Admissible inertia on axis 5*		0,42 kg x m <sup>2</sup>
Admissible inertia on axis 6*		0,18 kg x m <sup>2</sup>
Stroke /(Max Speed)	Axis 1	+/- 170° (360 °/s) **
	Axis 2	-64° / +114° (300 °/s) **
	Axis 3	-150° / +60° (330 °/s) **
	Axis 4	+/- 200° (500 °/s) **
	Axis 5	- 105°/ +100° (500 °/s) **
	Axis 6	+/- 2700° (800 °/s) **
Max horizontal reach		809 mm
Repeatability		+/- 0,03 mm
Robot weight		34 kg
Features of the tool coupling Robot wrist		ISO 9409 - 1 - A 25
Motors		AC Brushless
Position measurement system		Encoder
Protection degree		IP54
Mounting position		Floor, wall, ceiling
Operating environment temperature		5°C / +40°C
Storage temperature		-10°C / 55°C
Relative humidity		from 5% to 95% without condensation
Maximum temperature gradient		1,5 °C/min

\* Not allowed with maximum load

\*\* Maximum speed

\*\*\* Base vertical cable output available (option)

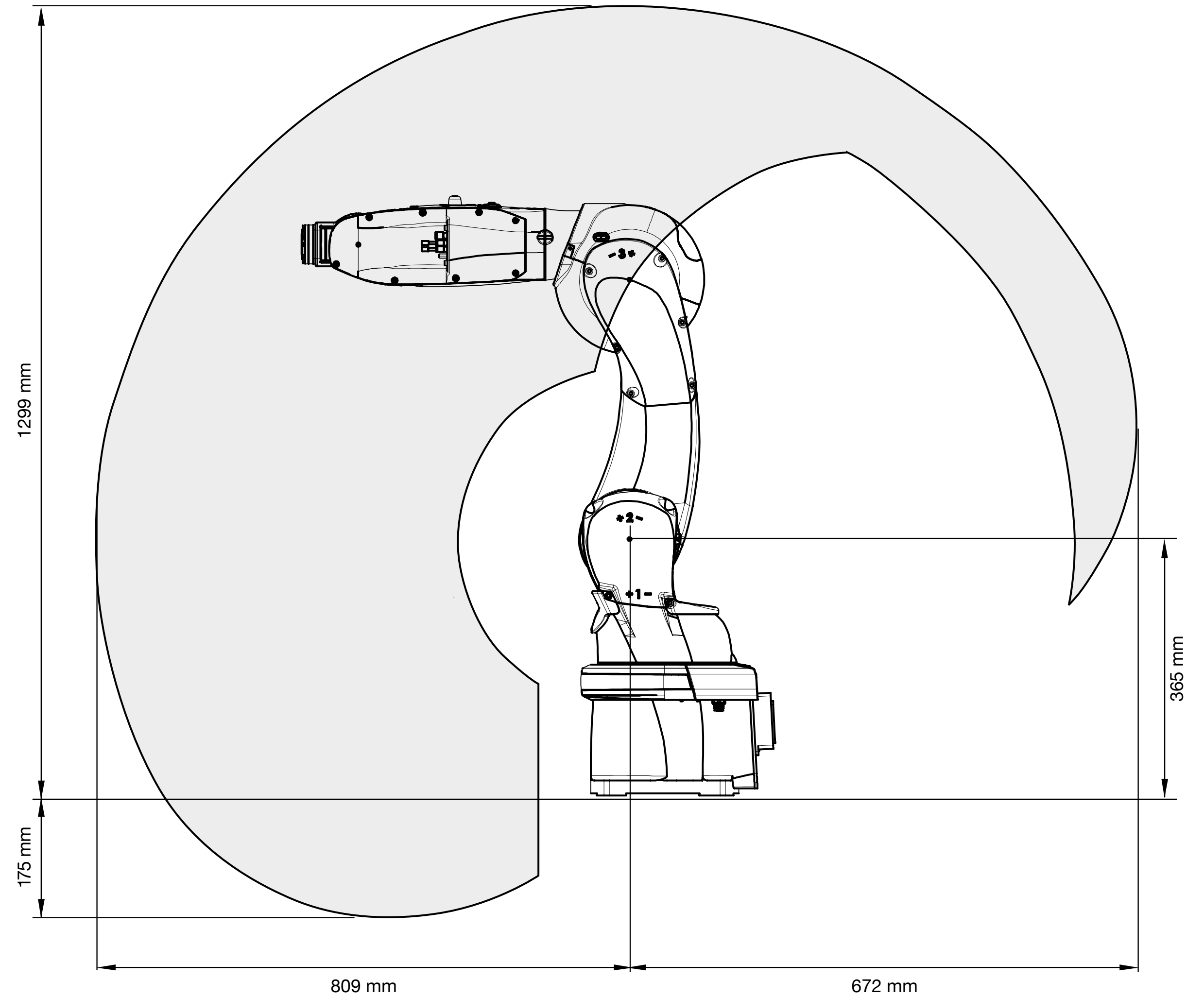



robotics.comau.com

Follow us



The contents of this brochure are supplied for general information only. Comau S.p.A. reserves the right to alter specifications at any time without notice for technical or commercial reasons. The illustration does not necessarily show the products in their standard version. **Edition Rev01 - 04/21 - Turin**

**Made in Comau**