

Max HT Air Heater

FOR SAFETY & LONG HEATER LIFE, CAREFULLY READ THIS MANUAL BEFORE USE.



CE

Safety



SHOCK HAZARD!

Only qualified individuals should install this heater and related controls. Follow all applicable electrical codes and use proper wiring.



BURN/FIRE/EXPLOSION HAZARD!

Do not use in hazardous environments, and/or near explosive or reactive gases, or combustible materials. Avoid contact with the heater or exit accessories during or soon after operation. **DO NOT USE NEAR VOLATILE OR COMBUSTIBLE MATERIALS.**

Description

The Max HT provides a compact, efficient heater for heating air or inert gases to 1652°F (900°C). The Max HT comes in various power ratings ranging from 18kW to 36kW. The heater is equipped with two (2) type “K” thermocouples. One thermocouple measures the inlet air temperature (S1) and the other is a dual probe type “K” thermocouple with each probe of the exit thermocouple used to measure exit air temperature. One is typically used for process temperature control and the other to monitor high temperature limit. When powered and controlled with OSRAM, Inc. approved controls (sold separately) you are provided a convenient, cost effective solution for safely controlling the AC power to your Max HT. If operated correctly, the heater will operate continuously for 5000 hours or longer.

Limited Warranty

TUTCO SureHeat warrants that all products to be delivered hereunder will be free from defects in material and workmanship at the time of delivery. TUTCO SureHeat's obligation under this warranty shall be limited to (at its option) repairing, replacing, or granting a credit at the prices invoiced at the time of shipment for any of said products. This warranty shall not apply to any such products which shall have been repaired or altered, except by TUTCO SureHeat, or which shall have been subjected. TUTCO SureHeat shall be liable under this warranty only if (A) TUTCO SureHeat receives notice of the alleged defect within sixty (60) days after the date of shipment; (B) the adjustment procedure hereinafter provided is followed, and (C) such products are, to TUTCO SureHeat's satisfaction, determined to be defective.

THE WARRANTY SET FORTH IN THE PRECEDING PARAGRAPH IS EXCLUSIVE AND IN LIEU OF ALL OTHER WARRANTIES, EXPRESS OR IMPLIED, INCLUDING, WITHOUT LIMITATION, ANY IMPLIED WARRANTY OF FITNESS FOR A PARTICULAR PURPOSE OR OF MERCHANTABILITY.

The information contained in this manual is based on data considered to be true and accurate. Reasonable precautions for accuracy has been taken in the preparation of this manual, however TUTCO SureHeat assumes no responsibility for any omissions or errors, nor assumes any liability for damages that may result from the use of the product in accordance with the information contained in this manual.

Please direct all warranty/repair requests or inquiries to the place of purchase, and provide the following information, in writing:

- (A) Order number under which products were shipped
- (B) Model/Serial Number of product
- (C) Reason for rejection

PRODUCTS CAN NOT BE RETURNED TO TUTCO SUREHEAT WITHOUT AUTHORIZATION.

Replacement, repair, or credit for products found to be defective will be made by the place of purchase. All products found to be not defective will be returned to the Buyer; transportation charges collect or stored at Buyers expense.

Heater Models and Parts List

Part Number	Maximum Wattage	Maximum Voltage	Maximum Amperage	Suggested wire size for 60°C cable*	Suggested wire size for 90°C cable*	Replacement Element
F077081	18.0kW	240 – 3Ø 50/60Hz	43.4	8	10	F206707
F077082	18.0kW	380 – 3Ø 50/60Hz	27.4	12	12	F206662
F077083	18.0kW	480 – 3Ø 50/60Hz	21.7	12	12	F206663
F077084	30.0kW	380 – 3Ø 50/60Hz	45.6	8	8	F206664
F077085	36.0kW	480 – 3Ø 50/60Hz	43.4	8	10	F206598

* Follow applicable electrical codes during installation

Specifications

Maximum Inlet Air Pressure 60 PSI (4 BAR)
 Maximum Inlet Air Temperature 200°F (93°C)
 Maximum Exit Air Temperature 1652°F (900°C)
 Minimum Airflow (Recommended) 18 SCFM (510 SLPM)

Exit Air Connection: 1-1/2" FNPT
 Inlet Air Connection: 1-1/4" FNPT
 Safety Approvals: UL Recognized, CE

Control/Limit Sensors: Type "K" isolated, ungrounded, exposed junction TCs:
 S1 measures inlet temperature
 Dual Probe Type "K" isolated, ungrounded, exposed junction TC
 (both used to measure exit temperature)

General Information

Environmental Conditions:
 Ambient Temperature 32°F to 104°F (0°C to 40°C)
 Humidity 0% to 95% R.H.

Ventilation:
 Use in a well-ventilated area away from excess dust, dirt, and moisture.

Cleaning:
 With unit OFF and unplugged, exterior surfaces may be wiped clean using a dry, lint-free cloth.

Protective Earthing:
 Each heater comes with a convenient grounding stud and hardware located at the inlet of the heater for protective means of earthing.

Dimensions/Mounting

NOTE: The inlet side of the heater is located where the leads/power feedthrus come out of the housing. Failure to install the heater in its proper orientation can result in heater damage and is not covered under the manufacturer's warranty.

Heater Dimensions:

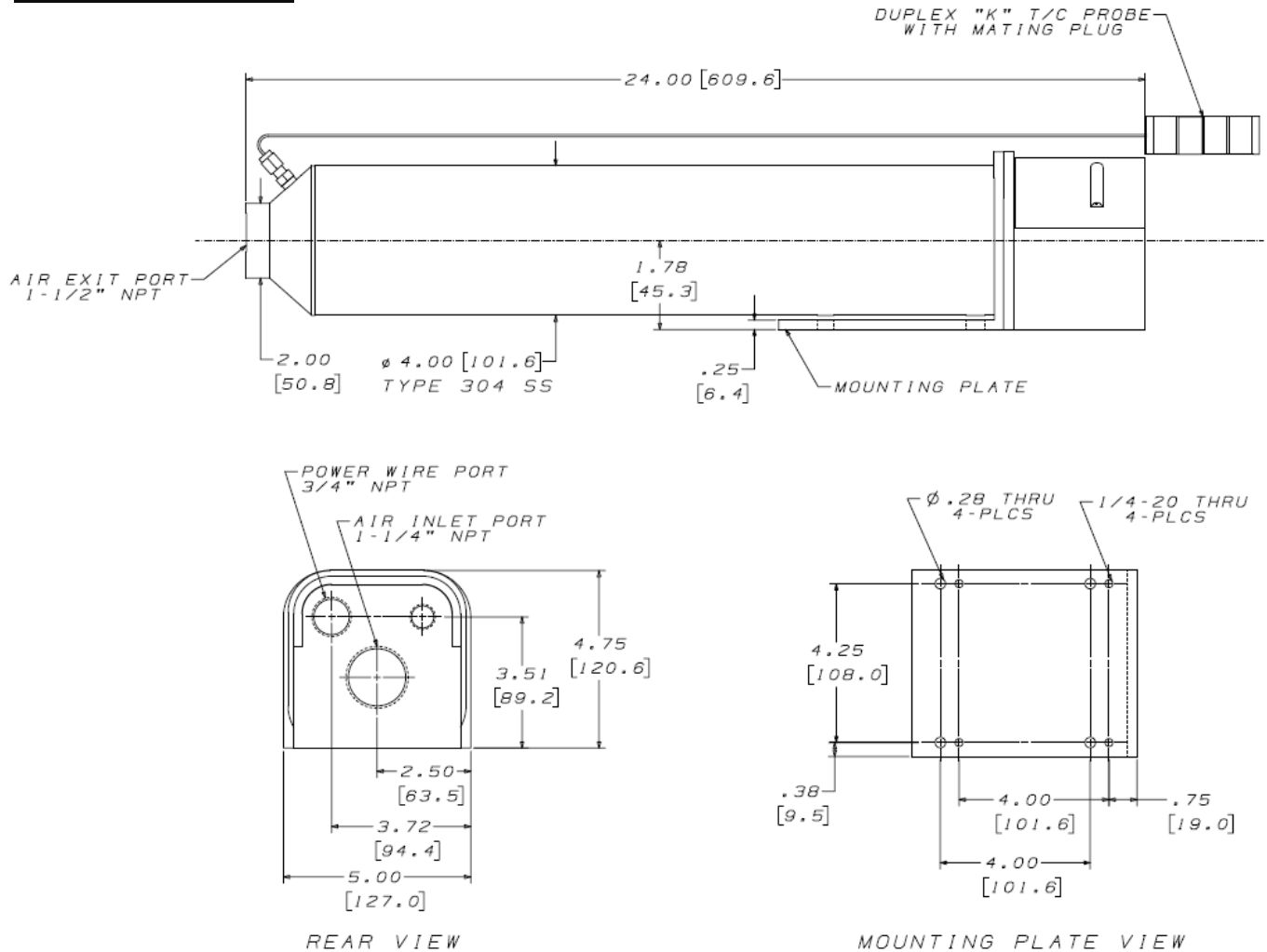

WARNING: Avoid Damage to Housing

3/8" NPT (Sensor): 4 ft-lb
 3/4" NPT (Power): 25 ft-lb
 1-1/4" NPT (Air): 7 ft-lb
 (Excessive force will crack housing and void warranty)

Precautions

1. Use filtered air. Avoid grease, oil, or oil vapors, corrosive or reactive gases which will damage heater.
Note: When using compressed air a pressure reduction valve and an oil & water separation unit should be installed to avoid contaminating the heater and reduce heater life.
2. Operate at safe voltages as shown on the Performance Curves (*see page 9*). Excess voltage will cause premature failure.
3. If using a process air temperature thermocouple other than one of the supplied “K” thermocouple probes it is highly recommended that one of the exit thermocouples be used with a temperature limiting board to protect against over temperature protection (TUTCO SureHeat Part #F076359 – set to 1680°F (915°C)).
4. If using closed-loop control, use a temperature controller with a fast sampling period (<500ms) and minimal overshoot.

Installation

Securely mount the heater before wiring.

- **WARNING:** THE INLET AIR/GAS SIDE OF THE HEATER IS THE PLASTIC HOUSING END WHERE THE POWER TERMINALS AND THERMOCOUPLE TERMINAL BLOCK IS LOCATED. INSTALLING THE HEATER IN THE WRONG ORIENTATION WILL DAMAGE THE HEATER AND CAN CREATE ADDITIONAL HAZARDS AS A RESULT. POWER CONNECTION WIRE SIZES ARE RECOMMENDED IN THE PRODUCT TABLE ABOVE. THESE ARE RECOMMENDATIONS ONLY, AND ALL LOCAL AND REGIONAL ELECTRICAL CODES SHOULD BE CONSULTED.

The following is a typical and recommended setup for the Max HT Heater. The Type “K” thermocouple sensors mounted outside the Max HT provide flexibility and safety for use with various control systems.

- Wire heater according to WIRING DIAGRAM shown. Follow applicable electrical codes when mounting and wiring system.
 - The configuration shown is recommended by TUTCO SureHeat for safe and optimum performance.
1. Note THREE (3) control devices are required for proper and safe heater operation, and should be mounted in an appropriate control cabinet:
 - i. **MAIN TEMPERATURE CONTROL**
 - Controls the heater process temperature
 - Can be 4-20mA output, or “Pulsed DC” output (0-10V, 3-32V, etc.)
 - Output type will depend on type of POWER CONTROL chosen.
 - Set to 1652°F (900°C) MAXIMUM to prevent overshooting and element failure.
 - A low temperature test run is suggested to verify the closed loop control (PID) settings are properly set. Overshoot and oscillating process temperature should be avoided to ensure long heater element life. (Contact the factory for assistance if needed)
 - ii. **INLET PRESSURE/FLOW SWITCH CONTROL**
 - Shuts the MAIN TEMP CONTROL output signal off is the heater is not supplied enough airflow.
 - The MINIMUM airflow needed to avoid damaging the heater is 18 SCFM (510 SLPM)
 - iii. **POWER CONTROL**
 - Regulates the AC voltage to the heater.
 - Select according to heater maximum voltage, and amperage.
 - Suitable POWER CONTROL types:
 1. “Zero-Cross Solid State Relay (SSR), (Pulsed DC Input) - or -
 2. “Phase-Angle” Fired Silicon Controlled Rectifier (SCR) (4-20mA Input)
 2. NOTE ON SENSOR CONNECTION
 - i. Type “K” thermocouple connects to EXIT TEMPERATURE CONTROL using Type “K” thermocouple wire.
 - ii. Note that YELLOW is POSITIVE and RED is NEGATIVE for these Thermocouple connections.
 3. NOTE ON POWER CONNECTIONS (L1, L2, L3, H1, H2, H3)

Power connection wire sizes are recommended in the Heater Models and Parts List located on page 3. These are recommendations only, and all local and regional electrical codes should be consulted.

 - i. LINE TO POWER CONTROL Fuses must be appropriately sized for maximum heater current.
 4. NOTE ON TEMPERATURE CONTROLS
 - i. The AC power source should be taken from the incoming line power (transformed as appropriate).
 - ii. The AC power source to the Temperature Controls should be energized simultaneously with power to the Power Control. This is usually done via circuit breaker or power disconnect switch on main control cabinet.

Typical Wiring:

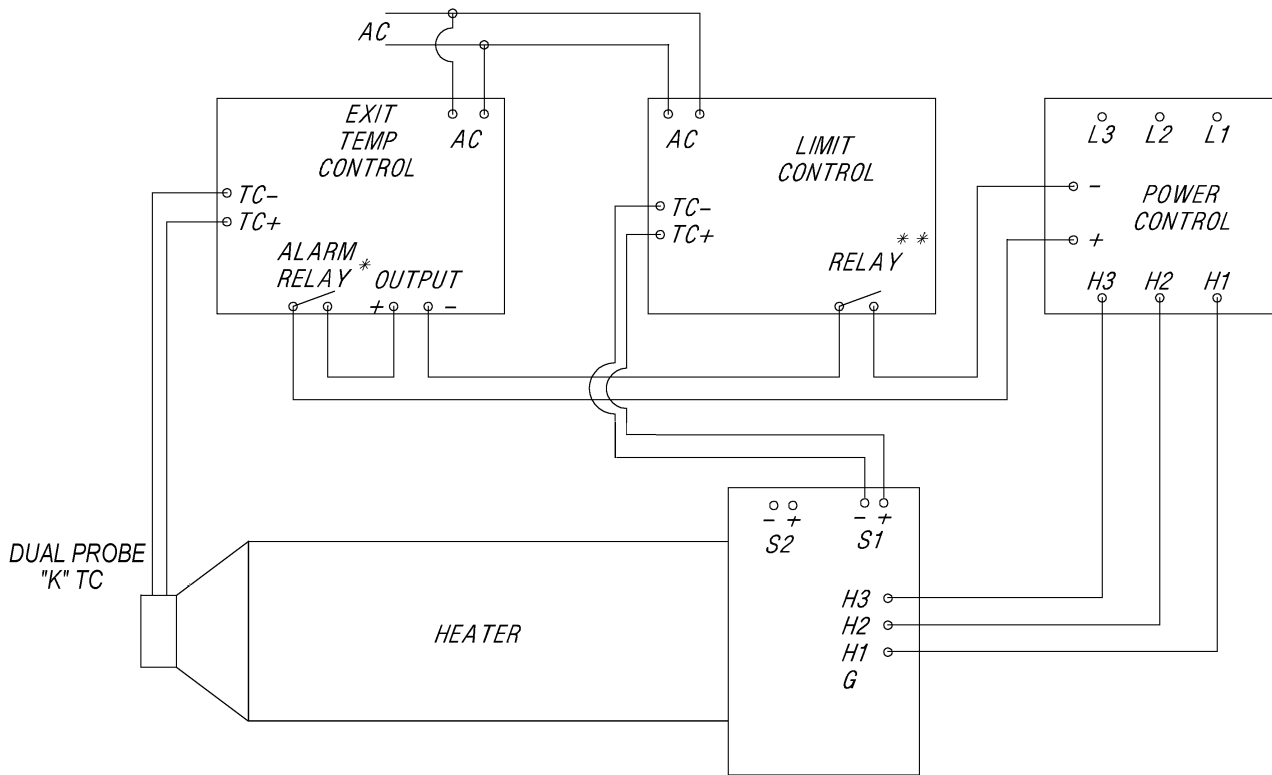

WIRING DIAGRAM
Max HT

* EXIT TEMP ALARM RELAY TO OPEN AT 905°C
 ** INLET LIMIT RELAY TO OPEN AT 150°C
 OTHER SETTINGS MAY DAMAGE HEATER AND VOID WARRANTY

Approved Control Parts

Part Number	Part	Description
F072765	Power Control	60A 480V Phase Angle Fired SCR; 4-20mA Input
F074829	Exit Temperature Control	1/16 DIN Digital Temperature Control; 4-20mA Output
F076359	Inlet/Exit Limit Control	Exit Limit Control with Relay Output; 0-1000°C

Operation (with Heater)

START-UP

1. Reference the Performance Curves section (*see page 9*) for operational parameters before attempting to operate heater(s).
2. Connect air source to heater.
3. Turn on air and set pressure or flow to desired operating level.
4. Energize MAIN POWER line; usually via disconnect switch or circuit breaker on control cabinet.
5. During operation, with constant airflow, the exit temperature will vary only a few degrees from set point. The heater should never be operated without airflow as excessive heat will damage either the element(s) and/or the plastic housing on the inlet side. The minimum airflow for the SureHeat® Max-HT is 18 SCFM.



Recommendation for first time Start-up: A low temperature test run is suggested to verify the closed loop control (PID) settings are properly set. Overshoot and oscillating process temperature should be avoided to ensure long heater element life. (Contact the factory for assistance if needed).

6. If using a closed loop system, turn on power to the temperature and power controller, then set the desired temperature on the temperature controller. It is recommended to use a ramp rate to set point. The approved OSRAM, Inc. temperature controllers have a ramp rate function. (Typical recommendation is 3 to 5 minutes). If using an open loop system, increase power to the heater through the power controller until the desired temperature is attained.

SHUT-DOWN

1. Turn off MAIN POWER line via disconnect switch or circuit breaker.
2. Allow air to continue to flow for a minimum of 1 minute or until exit air temperature is 300°F (150°C) or less for safety. Continue airflow longer as necessary to prevent burn hazard to personnel.
3. Turn off air to the system.

Performance Curves

Max HT Maximum Performance

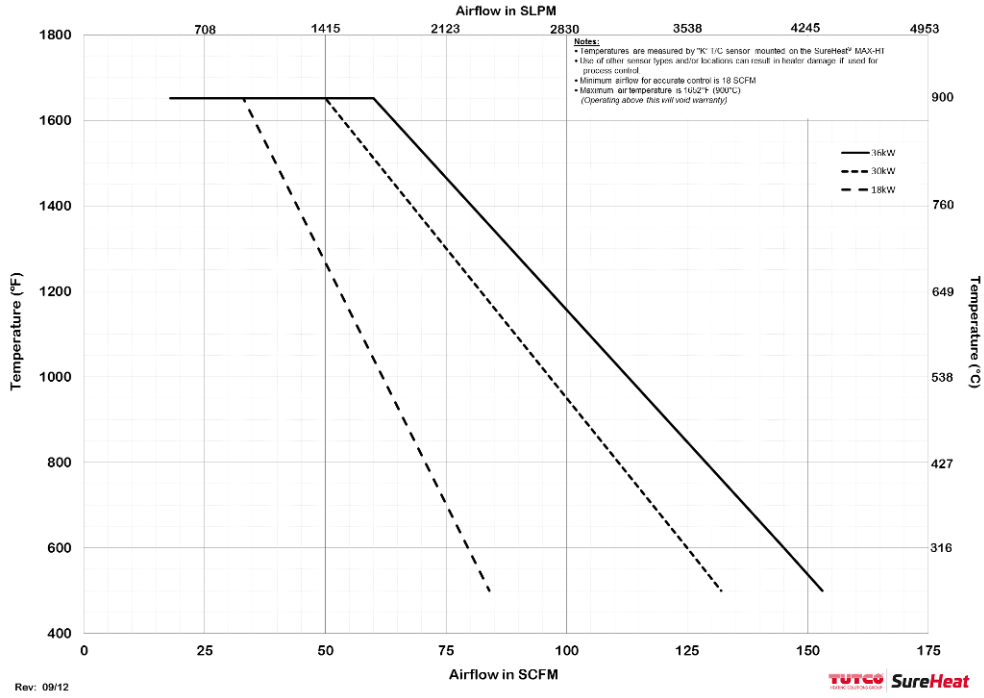

**Pressure Drop for Max HT
Operating at 900°C**

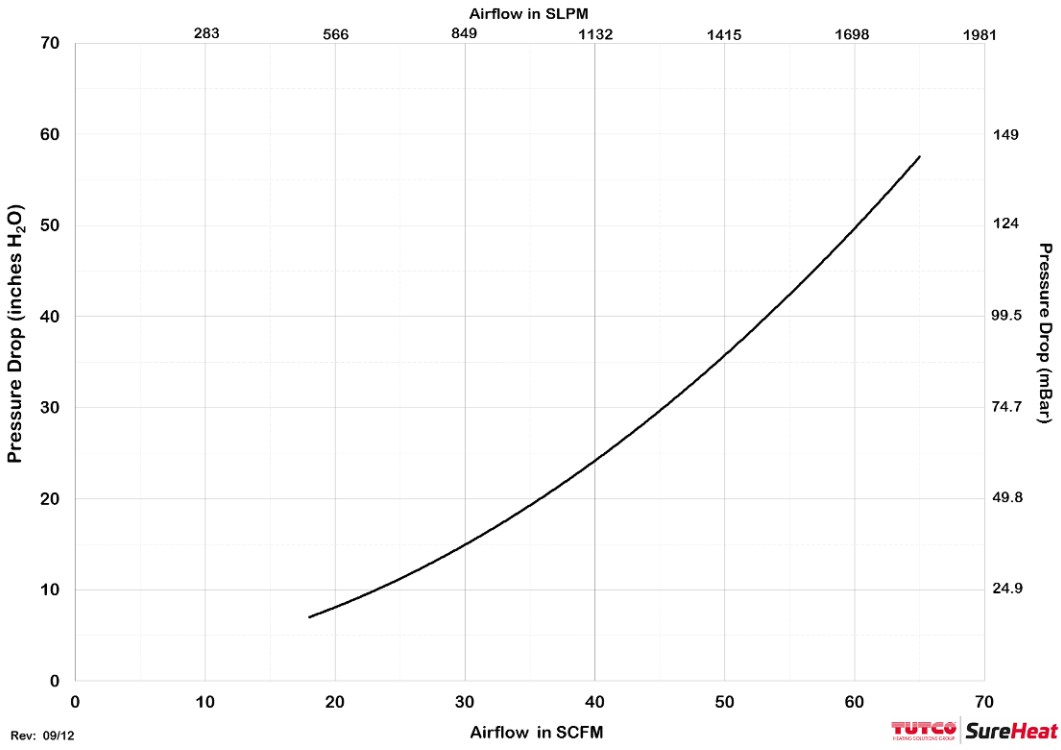

Troubleshooting and Replacing Heaters

1. Note that “TYPICAL” Element Life is APPROXIMATELY 5000 hours. This is based on heater element operating at or below temperatures shown on PERFORMANCE CURVE(S). In addition to normal end of life, elements can fail due to mechanical damage, or problems with the control system.
2. If an element has failed prematurely, it should be inspected to determine the cause of the element failure.
3. When replacing or troubleshooting heaters, turn off power to the system and be sure to follow lock-out/tag-out procedures.
 - a. For Troubleshooting Heater
 - i.) Use multi-meter to check continuity between:
 1. Power terminals H1-H2, H2-H3, and H1-H3
 2. Thermocouples positive (+ yellow) to negative (- red)
 - ii.) If there is continuity on all above tests, check system wiring:
 1. Crossed thermocouple wires.
 2. Reversed thermocouple wire polarity – Note: RED is NEGATIVE (-).
 3. Verify inlet air temperature is below set point on INLET TEMPERATURE controller.
 - iii.) If there is no continuity on any test, then contact your local OSRAM, Inc. representative for assistance.
4. Remove entire heater assembly from system. Internal components are typically not replaceable.
5. Reconnect thermocouples, power and ground wires for new/replacement heater.
6. Attach any covers and operate heater per operating manual.

Element Life Curve

(This is published by the element wire manufacturer. It is considered typically and not a guaranteed life)

The life of a TUTCO SureHeat heater is directly based on the temperature of the filament wire. The curve below shows that 5000 hours of life can be obtained by maintaining a filament temperature below 1900°F (1038°C). Also note that the element does not fail until it reaches more than 2200°F (1204°C)!

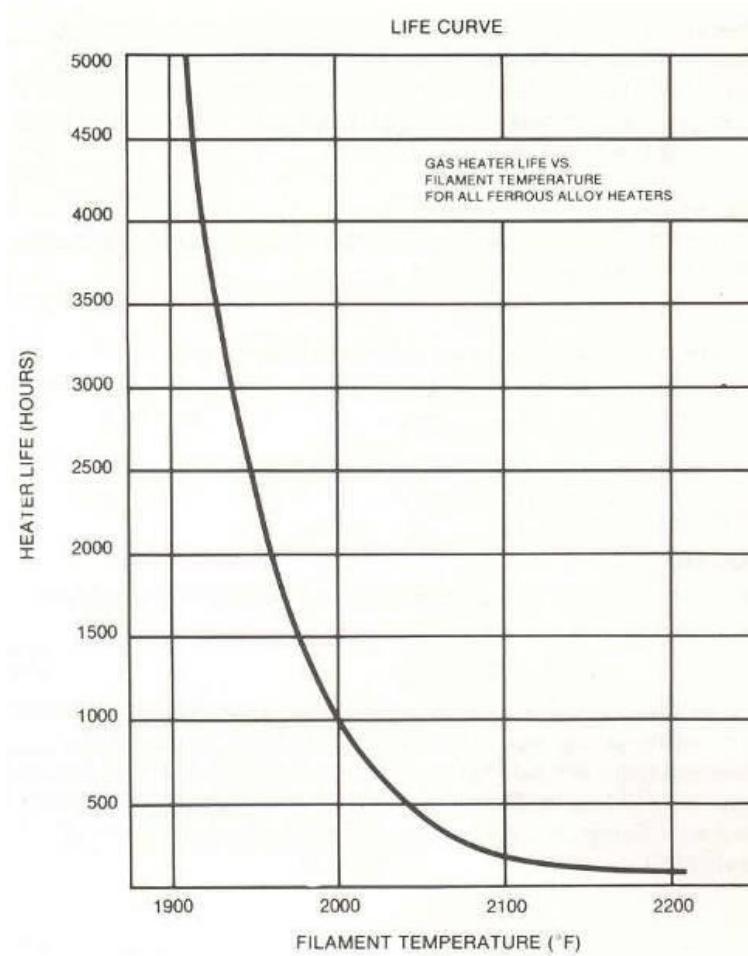

The technical data and specifications supplied in this operating manual are subject to change without prior notice. Contact TUTCO SureHeat for additional assistance.